



- All-in-one precision Frequency, Synchronising and Load Controller for single generator system
- Load control of generator paralleled to mains
- Fast precision "Spot-on" Synchronising of generator
- Frequency control
- Loading and offloading slope control, peak shaving, fixed load export, load limiting control, breaker trip and automatic reset facility
- Generator speed reference (analogue output)
- System status output

**Specifications**

Monitored Voltage Input:	100-120, 200-240, 380-415, or 440-460VAC, 40-70Hz (Fuse 0,5A)
Voltage Tolerance:	± 10%
Contact Rating:	AC: 100VA - 250V/2A max. DC: 50W - 100V/1A max.
Adjustments:	
Frequency difference:	+ 0, 1-2Hz
Volt differential:	+/- 2-15%
CB closing time:	30-300mS
Frequency reference:	48-62Hz
Pulse rate:	10-60 pr min
Pulse width:	0,1 to 1,6secs
Load trim:	0-110% kW nom.
Analogue input:	0-10mADC = 0-110% kW
*Analogue output:	-10/0/+10mADC = -5/0/+5Hz max 400ohm
*Optional output:	-3/0/+3VDC (-3/0/+3Hz) min 50kohm <i>*Only active when Sync. mode is selected</i>
Temperature:	-20 to +70°C
Weight:	0.7kgs
Front protection:	IP52 (IP65 optional)

Megacon is the inventor of the original, now industry standard "rotating" LED display, and a trendsetter in modern synchronisation control.

**Dimensions**

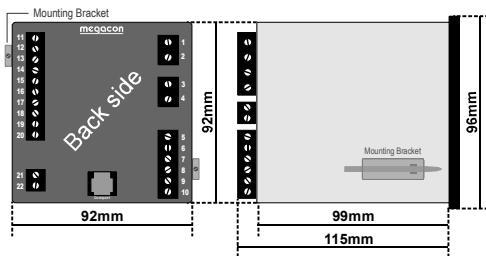

Unit meets IEC60092-504 and relevant environmental and EMC tests specified in IEC60068/60092 and IEC61000/60533 respectively, to comply with Classification Societies requirements.

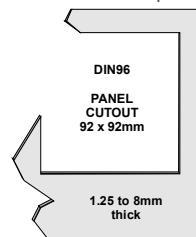

**Description**

The digitally controlled KSQ304E2 is an automatic one-generator co-generation or peak-shaving management system, which can be used with any make of GenSet starter together with Megacon's range of standard protective guards and controllers.

User settable limits on unit rear for frequency sync. difference, voltage differential, frequency reference, circuit breaker closing time, fuel regulator pulse width and pulse rate, load trim reference when paralleled to mains.

Note that the kW load signal input needs to be calibrated to be 0-110% of generator nominal load.

**Applications**

**Synchronising modes**

To adapt the functionality of KSQ304E2 to any specific application, the direction of approach to synchronising (LEAD, LAG or NEUTRAL) is factory set as required:

**LEAD** (incomer faster than mains), **LAG** (incomer slower than mains), **NEUTRAL** (bi-directional)

LEAD is the standard mode. The synchronising relay will then close when the frequency of the incomer is slightly HIGHER than the mains frequency. This avoids a non-stabilised incomer entering reverse power condition after synchronisation.

The rotary LED display indicates the incomer's speed relative to the mains, and is lit during frequency mode if the difference between the systems does not exceeds 5Hz.

During all modes the UP/DOWN arrows indicate the pulses from the raise/lower speed relays.

**Speed control**

The raise/lower relays pulse the fuel regulator or an interfacing MXR845x electronic potentiometer. Pulse width and rate can be adjusted to suit the dynamic response of any fuel regulator. The speed control has a P/I (proportional/integral) characteristic with a dynamically controlled dead zone.

Alternatively the linear analogue -10/0/+10mA output signal can be used as speed reference to a generator controller, with polarity and amplitude proportional to frequency difference between the two systems when synchronising mode is selected.

**System status:**

KSQ304E2 is fitted with a system status relay. As standard the unit is powered from generator side (terminal 3 & 4), when power is ok and unit is working correctly the relay activates. It will release on alarm or when unit is not powered. Separate auxiliary supply is needed for continuously system status.

Normal operation : Closed contact  
Alarm condition/unpowered : Open contact

**Connection**

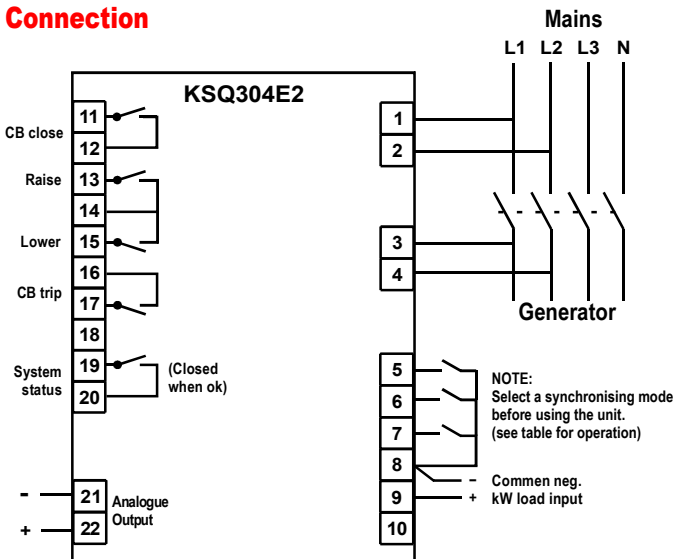

**System "P"**

"Spot-on" synchronising  
LEAD direction

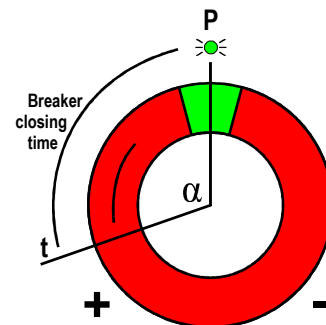

The breaker closure is initiated at "T" when the breaker coil is energised and finalises at "P", assuring a precise "12 o'clock" synchronisation. Allowed frequency difference is adjustable between 0.1Hz to 2Hz. The angle " $\alpha$ " varies according to the frequency difference between the two systems.

**The state of the digital inputs determines the operational mode of KSQ304E2**

Mode	Operation	Mode LED	Digital input state
<b>READY / FREQUENCY CONTROL MODE</b>	After the GenSet starter receives a START command the unit will be powered from the running generator voltage and enter <b>FREQUENCY CONTROL MODE</b> .	<b>FREQ</b> LED is lit during this mode	
<b>SYNCHRONISING MODE</b>	In <b>SYNCHRONISING MODE</b> unit will perform automatic synchronisation of generator to the mains. After synchronisation feedback from an auxiliary relay contact on the breaker will close Mode Control Terminal 6. The unit will then enter <b>LOAD CONTROL MODE</b> .	<b>SYNCH</b> LED is lit during this mode	
<b>LOAD CONTROL MODE</b>	Unit will operate in <b>LOAD CONTROL MODE</b> and control slope of generator loading and speed of engine to match kW export level set by the "Load Trim" potentiometer.	<b>LOAD</b> LED is lit during this mode	
<b>UNLOAD GENERATOR / BREAKER TRIP MODE</b>	After receiving an unload command (close terminal 7) unit will enter <b>GENERATOR UNLOAD MODE</b> , reducing speed of engine and offload the generator load at a controlled slope. When offloaded (kW = nil), unit enters <b>BREAKER TRIP MODE</b> and gives <b>ONE</b> breaker trip pulse to open the generator breaker. When breaker has tripped remove the unload command to revert to <b>FREQUENCY CONTROL MODE</b> keeping the generator at nominal speed and ready to be paralleled back to mains <b>OR</b> to enter cooling down period.	<b>LOAD</b> LED flashes during this mode	

**Applications**

**"SPOT ON" synchronisation - CB closing time compensation**

The dynamically controlled CB closing time compensation provides **SMOOTH** synchronising, avoiding the engine/generator couplings being exposed to excessive torque forces. If **FAST** synchronisation is the priority, accurate "SPOT-ON" synchronising will still be maintained even with a large frequency difference between the power sources. Typical setting for **smooth synchronising** is 0,2-0,3Hz. The synchroniser operation and accuracy is not influenced by distorted voltage waveforms or harmonics.

**Synchronisation**

Green LEDs indicate voltage presence on supply source (BUS PWR/MAINS only when generator is powered) and incoming generator (GEN PWR). Green LEDs also indicate that the voltage and frequency differentials between the two systems are within limits. The synchronising relay will close when the above conditions are achieved.

A green LED "CB CLOSE" indicates the closing command to the breaker. If any red LED is lit voltage and/or frequency is outside the set limits for synchronising.

**Note:** The CB Close LED will flash when unit is ready for synchronising, but inhibit input is open or synchronising mode is not selected.

The MEGACON policy is one of continuous improvement, consequently equipment supplied may vary in detail from this publication.

**ORDERING INFORMATION**  
 Product type : KSQ304E2  
 Network voltage : 230VAC  
 Aux. supply : 230VAC

