



- Precision Check Synchroniser, Sector principle
- Speed raise/lower relay outputs
- Dead-bus facility
- Integral voltage differential protection, adjustable
- Bi-directional synchronising
- "Easy view" status presentation
- Generator speed reference (analogue output)
- System status output

Specifications

Monitored Voltage	25-500VAC, 40-70Hz
Input:	
Aux. Supply:	AC: 100-120, 200-240, 380-415, or 440-460VAC, 40-70Hz (Fuse 0,5A) DC: 24 or 36-160V (Fuse 2A)
Voltage Tolerance:	± 10%
Contact Rating:	AC: 100VA - 250V/2A max. DC: 50W - 100V/1A max.
Adjustments:	
Phase angle:	4-30 degrees
Retention time:	100-600mS
High voltage:	2-15% of net voltage
Low voltage:	2-15% of net voltage
Pulse rate:	12-60 pr min
Pulse width:	120mS to 1,6secs
*Analogue output:	-10/0/+10mADC = -5/0/+5Hz max 400ohm
*Optional output:	-3/0/+3VDC (-3/0/+3Hz) min 50kohm <i>*Only active when Sync. mode is selected</i>
Temperature:	-20 to +70°C
Weight:	0.7kgs
Front protection:	IP21

Unit meets IEC60092-504 and relevant environmental and EMC tests specified in IEC60068/60092 and IEC61000/60533 respectively, to comply with Classification Societies requirements.

Megacon is the inventor of the original, now industry standard "rotating" LED display, and a trendsetter in modern synchronisation control.

Description

KCQ333EJD52x provides both visual speed rotation, phase angle relationship and raise/lower speed relay signals necessary to achieve automatic check synchronising of two different system voltages. When used as a dead-bus coupler, the CB close relay will energise when busbar I is "dead" and the enable signal is closed.

KCQ333EJD52A as standard is powered from the monitored voltage on terminal 3 & 4. KCQ333EJD52B have separate auxiliary supply on terminal 19 & 20.

The synchronising relay will close when the incomer (generator, busbar, etc.) voltage and phase angle have been within the limits during the set retention time.

A green lamp (CB close) indicates the close command to the breaker.

There is lamp indication for reference source present (BUS PWR) and incomer status (GEN PWR).

A green lamp (VOLT OK) is lit when both voltages are within the set limits.

While the generator is running close to synchronising speed the **synch-on-hold** function can inhibit synchronising. This feature allows the operator to determine the moment to enable synchronising. Open link between terminal 7 & 8 to inhibit. LED "CB CLOSE" flashes during inhibit condition.

Applications

KCQ333EJD52x can be used both for single and three phase systems. Any two phases (or phase-neutral) can be used for synchronising as long as it is the same two phases on both side of the breaker.

User settable voltage limits, retention time, phase angle and pulse rate and width on the rear.

The analogue -10/0/+10mA output signal can be used as speed reference to a generator controller, with polarity and amplitude proportional to frequency difference between the two systems.

System status:

KCQ333EJD52x is fitted with a system status relay. When power is ok and unit is working correctly the relay activates. It will release on alarm or when unit is not powered.

- Normal operation : Closed contact
- Alarm condition/unpowered : Open contact

Connection

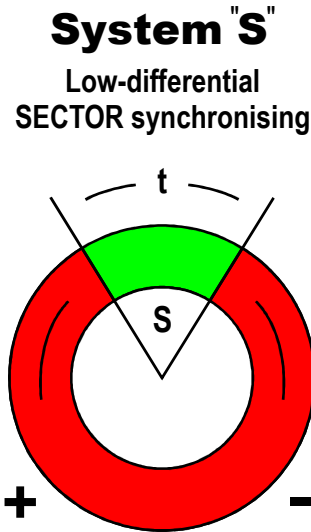
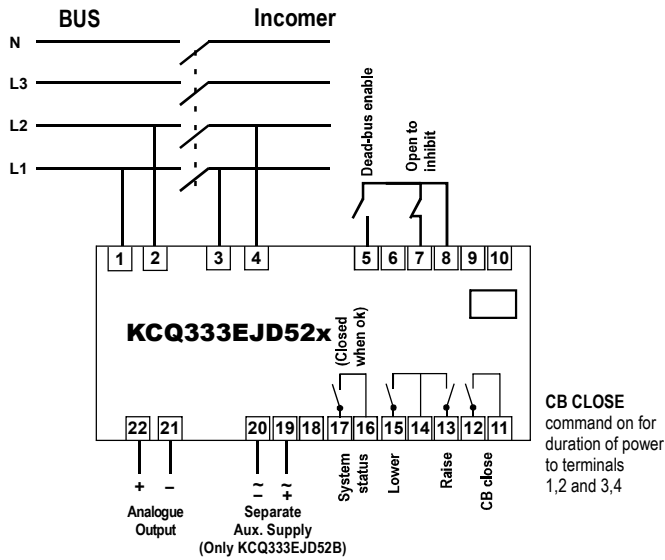

Description

System "S" the sector synchronising principle:

The KCQ333EJD52x is a low differential bi-directional bus coupler synchronising relay. The synchronising relay closes when the incomer (generator, busbar, etc.) frequency is close enough (diff 0,018 - 0,83Hz) to stay within the phase angle sector (S) for the set retention period (t).

Sector synchronisation is the classical alternative for applications which allows synchronisation accuracy and duration of synchronisation process to be interrelated. There is no compensation for the breaker closing time.

Approximate synchronisation accuracy relative to 12 o'clock position (Df) can be calculated by the following formula:

$$Df = (S : 360) / t (\text{secs})$$

Example: Set phase angle (S) to 10 degrees and retention time (t) to 500ms to obtain an accuracy of Df:
 $(10/360) / 0,5 = 0,055\text{Hz}$

If the phase angle limit is set too low and retention time too high for very low differential synchronising, it can be difficult to achieve synchronisation. If there is a continuously fluctuating load between the two systems (for example to synchronise against a shaft generator when a vessel is in rough weather), the KCQ104x2 "SPOT-ON" principle is more suitable.

The "phase angle" setting on the front of the unit refers to the total phase angle sector (S), centred about 0°. Hence a setting of 10° means the sector spanning from -5° to +5°.

Note: The CB Close LED will flash when unit is ready for synchronising, but inhibit input is open or synchronising mode is not selected.

Dimensions

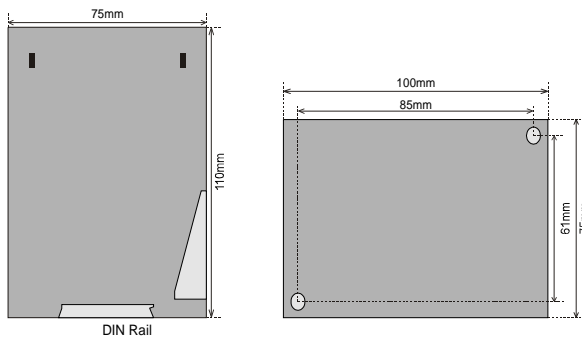

Operation

Gen.	Bus	Dead-Bus Enable	Operation
Dead	Live	Closed	CB close
Live	Dead	Closed	CB Close
Dead	Dead	Closed	No CB close
Live	Live	N/A	Normal Synch.

The MEGACON policy is one of continuous improvement, consequently equipment supplied may vary in detail from this publication.

ORDERING INFORMATION

Product type : KCQ333EJD52B
Auxiliary supply : 110VDC
Network voltage : 415VAC

