



- The fast "Spot-on" synchroniser
- LEAD and/or LAG synchronising facility
- Breaker closing time compensation
- Frequency differential analogue output
- "Easy view" status presentation
- Generator speed control (relays)
- Generator speed reference (analogue output)
- System status output

Specifications

Monitored Voltage Input:	100-120, 200-240, 380-415, or 440-460VAC, 40-70Hz (Fuse 0,5A)
Separate Aux. Supply (Only for KCQ104G2)	AC: 100-120, 200-240, 380-415, or 440-460VAC, 40-70Hz (Fuse 0,5A) DC: 24 or 36-160V (Fuse 2A)
Monitored Voltage: (Only for KCQ104G2)	25-500VAC, 40-70Hz
Voltage Tolerance:	± 10%
Contact Rating:	AC: 100VA - 250V/2A max. DC: 50W - 100V/1A max.
Adjustments:	
Frequency diff:	0,1-2Hz
CB closing time:	30-300mS
High voltage:	2-15% of net voltage
Low voltage:	2-15% of net voltage
Pulse rate:	12-60 pr min
Pulse width:	120mS to 1,6secs
*Analogue output:	-10/0/+10mADC = -5/0/+5Hz max 400ohm
*Optional output:	-3/0/+3VDC (-3/0/+3Hz) min 50kohm <i>*Only active when Sync. mode is selected</i>
Temperature:	-20 to +70°C
Weight:	0.7kgs
Front protection:	IP21

Unit meets IEC60092-504 and relevant environmental and EMC tests specified in IEC60068/60092 and IEC61000/60533 respectively, to comply with Classification Societies requirements.

Megacon is the inventor of the original, now industry standard "rotating" LED display, and a trendsetter in modern synchronisation control.

Description

The digitally controlled KCQ104x2 provides presentation of voltage differential, relative speed and speed control output signals necessary to achieve fast, automatic "spot-on" synchronising between two systems. The KCQ104x2 is a direct replacement for the traditional KCQ104.

Its many important features contribute to make the KCQ104x2 simply the best choice available for synchronising in any automatic generator control system (PM-system).

KCQ104F2 is the standard and it takes the auxiliary voltage from the monitored voltage on terminal 3 & 4. KCQ104G2 have separate auxiliary supply on terminal 19 & 20.

Applications

KCQ104x2 is used for both single and three phase systems. Any two phases (or phase-neutral) can be used for synchronising as long as they are the same two phases on both sides of the breaker. The synchroniser is rated for continuous operation and can be left connected when not in use.

Synchronising modes

To adapt the functionality of the KCQ104x2 to any specific application, the direction of approach to synchronise an incomer (generator, busbar, etc.) can be selected as required:

LEAD (incomer faster than bus), **LAG** (incomer slower than bus), **NEUTRAL** (bi-directional)

LEAD is generally the preferred mode. The synchronising relay will then operate when the frequency of the incomer is slightly HIGHER than the bus frequency. This is to avoid motoring of the incomer (entering a reverse power condition) after the breaker is closed.

The up and down arrows indicate the incomer's speed relative to the bus.

Speed control

The raise/lower relays pulses the fuel control governor motor, or an interfacing MXR845x electronic potentiometer. Pulse length and rate of the speed control relays are adjusted on the rear of the unit to suit the dynamic response of any engine regulator. The speed control has a P/I (proportional/integral) characteristic, with a dynamically controlled dead zone.

Alternatively the analogue -10/0/+10mA output signal can be used as speed reference to a generator controller, with polarity and amplitude proportional to frequency difference between the two systems.

System status

KCQ104x2 is fitted with a system status relay. As standard the unit is powered from generator side (terminal 3 & 4), when power is ok and unit is working correctly the relay activates. It will release on alarm or when unit is not powered. Separate auxiliary supply is needed for continuously system status.

Normal operation : Closed contact
Alarm condition/unpowered : Open contact

Connection

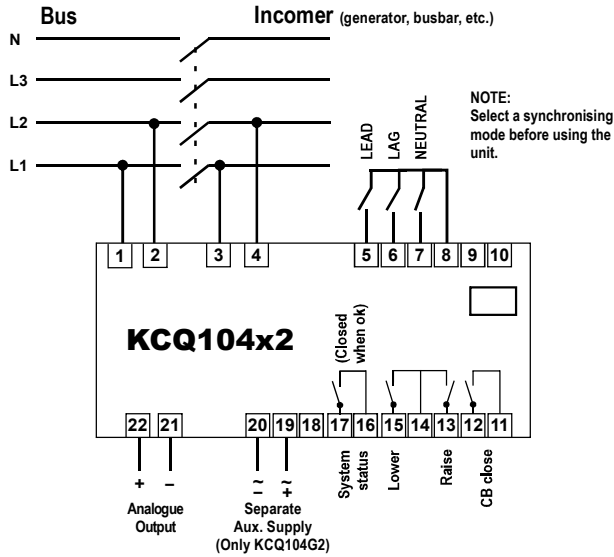

System "P"
"Spot-on" synchronising
LEAD direction

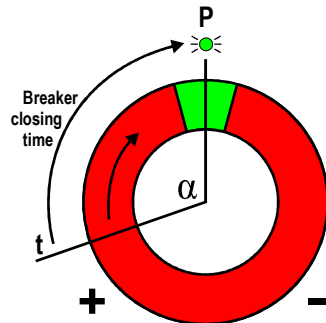

Fig.1

System "P"
"Spot-on" synchronising
LAG direction

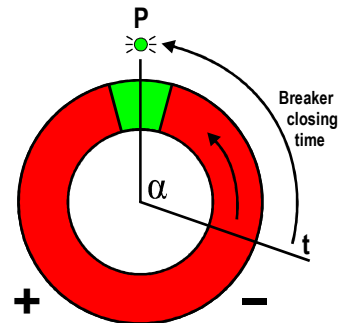

Fig.2

Description

“SPOT ON” synchronisation - CB closing time compensation

The dynamically controlled CB closing time compensation provides **SMOOTH** synchronising, avoiding the engine/generator couplings being exposed to excessive torque forces. If **FAST** synchronisation is the priority, accurate "SPOT-ON" synchronising will still be maintained even with a large frequency difference between the power sources.

The System "P" synchronising principle

The relay closure is initiated at "T" when the breaker coil is energised and finalises at "P", assuring a precise "12 o'clock" synchronisation (figs 1 and 2). Allowed frequency difference is adjustable between 0.1Hz and 2Hz.

Typical setting for **smooth synchronising** is 0,2Hz. The angle "a" varies according to the calculated frequency difference between the two systems. The synchroniser operation and accuracy is not influenced by distorted voltage waveforms or harmonics.

Synchronisation

Green lamps indicate voltage presence on reference source (BUS PWR) and incoming generator (GEN PWR). Green lamps also indicate that the voltage and frequency differentials between the two systems are within the limits. The synchronising relay will close when the above conditions are achieved.

A green lamp (CB close) indicates the close command to the breaker. Frequency difference and voltage limits, circuit breaker closing time, speed control relays pulse length/rate and synchronising mode are user settable on the front of the unit.

Note: The CB Close LED will flash when unit is ready for synchronising, but inhibit input is open or synchronising mode is not selected.

Dimensions

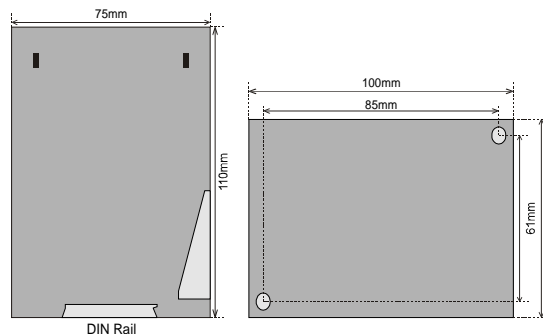

The MEGACON policy is one of continuous improvement, consequently equipment supplied may vary in detail from this publication.

ORDERING INFORMATION

Product type	: KCQ104G2
Auxiliary supply	: 230VAC
Network voltage	: 450VAC

