



- Direct connection up to 690V line voltage, up to 25kV with HV adapter for both single or three phase systems
- Monitoring during both live and standby conditions
- For use in land, marine, offshore, sub-sea and ocean floor Installations
- Complies with IMCA D 045 Code of Practice
- "Megger" - safe to 1.4kVDC when aux power is OFF
- Immune to earth capacitance and voltage surges
- Analogue output proportional to meter reading (F-version)
- Optional slave indicator

Specifications

Auxiliary Supply:	100-120, 200-240, 380-415 or 440-460VAC, 40-70Hz (Fuse 0.5A)
Optional Voltage:	12-24, 48 or 110VDC (Fuse 2A)
Supply tolerance:	± 10%
Power rating:	1,5VA
Contact rating:	AC: 100VA - 250V/2A max. DC: 50W - 100V/1A max.
Analogue Output:	Up to 20mA, max 500R
F-versions	Up to 10V, min 100kohm (other on request)
Temperature:	-20 to +70°C
Weight:	0.6kgs
Front protection:	IP21

INTELLIGENT SETTING ASSISTANCE

KCM165x has a built-in Assistance tool for setting/verification of the trip levels and the analogue output.

When either the **Warning** or **Alarm** potmeter on the front is operated by user, the slave meter goes into **Assistance Mode** and meter reading and analogue output will reflect the potmeter setting.

How to set alarm levels:

Firstly adjust potmeter fully clockwise (see that meter goes to the top), then adjust potmeter down to required **Warning** or **Alarm** setpoint. In this mode, the Alarm or Warning LEDs (depending on which potmeter is adjusted) will flash quickly Red/Yellow.



Without any movement of potmeters, the meter will revert to normal Insulation Monitoring Mode after approximately 10 seconds.

How to test analogue output signal:

Adjust any trip level potmeter to activate Assistance Mode.
Example: On a 4-20mA output, adjust potmeter fully anti clockwise for 4mA and fully clockwise for 20mA.

The KCM165x range is designed to comply with specification IMCA D 045 "Code of Practice for the Safe Use of Electricity Under Water" issued by IMCA.

The unit meets IEC60092-504 and the relevant environmental and EMC tests specified in IEC60068/60092 and IEC61000/60533 respectively, to comply with the requirements of the major Classification Societies.

Application

The digitally controlled KCM165x series monitors insulation level between a non-grounded (IT) AC mains and its protective earth, regardless of whether the mains is live or non-live (standby). The unit is for land, marine, offshore, sub-sea and ocean floor use.

An AC or DC auxiliary voltage is required for the unit, if powered from a separate source the network can also be monitored during standby conditions. Only **ONE** KCM165x can be connected to each IT-system. The ohmmeter and the triple-zone status LEDs give at a glance the clear safety message:

- ALARM (red zone)
- WARNING (yellow zone)
- HEALTHY (green zone)

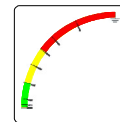

General

IDV MEASURING PRINCIPLE

Insulation is measured between the complete galvanically interconnected AC network and its protective earth.

The unit injects a DC voltage signal into the monitored system. The signal flows to ground via the path of the insulation fault, the level of flow indicates the insulation resistance. The measuring accuracy is not influenced by any normal kind of load attached to the AC network.

Trip levels and delays are settable on unit rear. A trip LED flashes when the trip level is passed, the relay trips when the delay has elapsed. The timer resets if the fault is removed during countdown.

MEGGER SAFE

When auxiliary power is **OFF** the unit input is automatically protected against "megger" test voltages up to 1.4kVDC, and incorrect measurements caused by the unit's input impedance are avoided.

OUTPUTS

All F versions have an isolated **analogue output** proportional to meter reading. If output is used for remote meter reading, we recommend 0-1mA for the slave indicator.

SAFETY

When a voltage adapter (ARx or ANx) is used the signal to terminals 4 and 6 on KCM165x is limited to a safe level, avoiding any dangerous voltage exposure to personnel.

Description

KCM165H & KCM165HF - KCM165HG & KCM165HGF

Start of monitoring has a 30 secs delay. This unit is for marine, offshore, sub-sea and ocean floor use. It has a wide measuring range in order to detect degradation of insulation at its origin. An important feature is the unit's unique inhibit function, controlled by the **Load Distortion and Earth-capacitance Detector (LDED)**.

The **LDED** function differentiates between a true (resistive) or a false (capacitive) drop in insulation reading, and will maintain reliable and accurate insulation monitoring even if load switching or a major change in load spread capacitance cause meter indication to drop **below** set relay trip levels. This situation may occur due to the latent high RC product at the high end part of the measuring range. The LDED will then momentarily inhibit all monitoring functions, freeze operation of meter, lamp display, alarm relays and analogue output for duration of a monitoring irregularity.

The unit will restore normal operation at the moment meter deflection rises **above** set alarm trip levels. The **LDED** function has **minimum 5 secs detection time for any insulation fault**.

Direct connection up to 690V line voltage. Up to 25kV via HV adaptor ARx or ANx series.

Output diagram

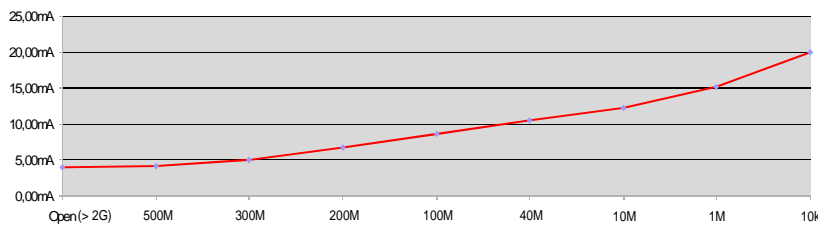

Relay Operation

Scale range: 10kΩ-500MΩ - ∞ (>2GΩ)

	Warning	Alarm	Fail Safe	Latch
R1	✓			
R2		✓	✓	* / ✓
R3		✓	✓	* / ✓

Model	Latch	Output	Adjustments	Trip level	Delay
KCM165H	-	-	WARNING:	10kΩ-400kΩ	0-30secs
KCM165HF	-	X	ALARM:	10kΩ-400kΩ	0-30secs
KCM165HG*	X	-			
KCM165HGF*	X	X			

Coloured sectors show recommended areas of settings:
■ - Indicates alarm trip zone
■ - Indicates warning trip zone
■ - Indicates healthy zone

Output table (example for 4-20mA) Range (slave indicator)

Value (scale)	mA output
10kΩ	20.00mA
1MΩ	14.84mA
10MΩ	12.28mA
40MΩ	10.57mA
100MΩ	8.63mA
200MΩ	6.64mA
300MΩ	4.93mA
500MΩ	4.20mA
Open (>2GΩ)	4.00mA

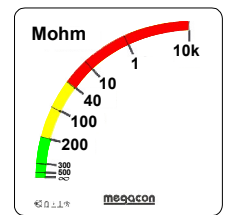

Description

KCM165G1 & KCM165GF1 - KCM165L1 & KCM165LF1

Start of monitoring has a 30 secs delay. This unit is for marine, offshore, sub-sea and ocean floor use. It has a wide measuring range in order to detect degradation of insulation at its origin. An important feature is the unit's unique inhibit function, controlled by the **Load Distortion and Earth-capacitance Detector (LDED)**.

The **LDED** function differentiates between a true (resistive) or a false (capacitive) drop in insulation reading, and will maintain reliable and accurate insulation monitoring even if load switching or a major change in load spread capacitance cause meter indication to drop **below** set relay trip levels. This situation may occur due to the latent high RC product at the high end part of the measuring range. The LDED will then momentarily inhibit all monitoring functions, freeze operation of meter, lamp display, alarm relays and analogue output for duration of a monitoring irregularity.

The unit will restore normal operation at the moment meter deflection rises **above** set alarm trip levels. The **LDED** function has **minimum 5 secs detection time for any insulation fault**.

Direct connection up to 690V line voltage. Up to 25kV via HV adaptor ARx or ANx series.

Output diagram

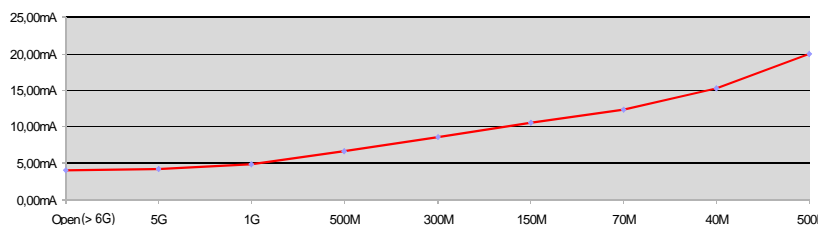

Relay Operation

Scale range: 500kΩ-5GΩ - ∞ (>6GΩ)

	Warning	Alarm	Fail Safe	Latch
R1	✓			
R2		✓	✓	* / ✓
R3		✓	✓	* / ✓

Model	Latch	Output	Adjustments	Trip level	Delay
KCM165G1*	X	-	WARNING:	500kΩ-3GΩ	0-30secs
KCM165GF1*	X	X	ALARM:	500kΩ-3GΩ	0-30secs
KCM165L1	-	-			
KCM165LF1	-	X			

Coloured sectors show recommended areas of settings:
■ - Indicates alarm trip zone
■ - Indicates warning trip zone
■ - Indicates healthy zone

Output table (example for 4-20mA) Range (slave indicator)

Value (scale)	mA output
500kΩ	20.00mA
40MΩ	15.18mA
70MΩ	12.28mA
150MΩ	10.57mA
300MΩ	8.63mA
500MΩ	6.64mA
1GΩ	4.93mA
5GΩ	4.20mA
Open (>6GΩ)	4.00mA

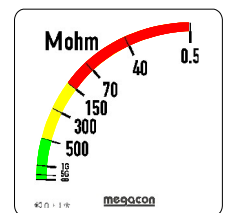

The MEGACON policy is one of continuous improvement, consequently equipment supplied may vary in detail from this publication.



Description

KCM165E1 & KCM165F1 - KCM165N1 & KCM165NF1

Start of monitoring has a 30 secs delay. This unit is for marine, offshore, sub-sea and ocean floor use. It has a wide measuring range in order to detect degradation of insulation at its origin. An important feature is the unit's unique inhibit function, controlled by the **Load Distortion and Earth-capacitance Detector (LDED)**.

The **LDED** function differentiates between a true (resistive) or a false (capacitive) drop in insulation reading, and will maintain reliable and accurate insulation monitoring even if load switching or a major change in load spread capacitance cause meter indication to drop **below** set relay trip levels. This situation may occur due to the latent high RC product at the high end part of the measuring range. The LDED will then momentarily inhibit all monitoring functions, freeze operation of meter, lamp display, alarm relays and analogue output for duration of a monitoring irregularity.

The unit will restore normal operation at the moment meter deflection rises **above** set alarm trip levels. The **LDED** function has **minimum 5 secs detection time for any insulation fault**.

Direct connection up to 690V line voltage. Up to 25kV via HV adaptor ARx or ANx series.

Output diagram

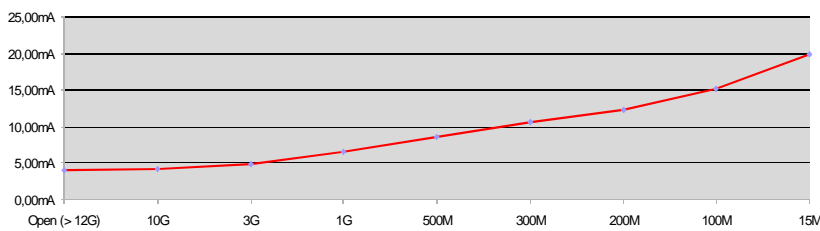

Relay Operation

Scale range: 15MΩ-10GΩ - ∞ (>12GΩ)

	Warning	Alarm	Fail Safe	Latch
R1	✓			
R2		✓	✓	* /
R3		✓	✓	* /

Model	Latch	Output	Adjustments	Trip level	Delay
KCM165E1*	X	-	WARNING:	15MΩ-5GΩ	0-30secs
KCM165F1*	X	X	ALARM:	15MΩ-5GΩ	0-30secs
KCM165N1	-	-			
KCM165NF1	-	X			

Coloured sectors show recommended areas of settings:
 - Indicates alarm trip zone
 - Indicates warning trip zone
 - Indicates healthy zone

Output table (example for 4-20mA)

Value (scale)	mA output
15MΩ	20.00mA
100MΩ	15.18mA
200MΩ	12.28mA
300MΩ	10.57mA
500MΩ	8.63mA
1GΩ	6.64mA
3GΩ	4.93mA
10GΩ	4.20mA
Open (>12GΩ)	4.00mA

Range (slave indicator)

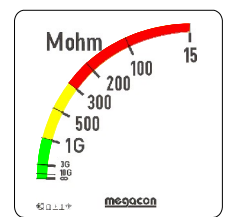

High Voltage Adaptors up to 25kVAC for KCM165x series

- HV Adaptor for AC Insulation Guards
- ARx series, up to 14kV Line Voltage live or non-live (standby)
- ANx series, up to 25kV System Voltage live or non-live (Starpoint/Neutral connection only)
- Creates safety barrier from live HT network to LV switchboard
- Limits measuring output signal to safe levels
- No restrictions on distance between adapter and LV switchboard

Voltage Adaptors ARx and ANx are used together with Insulation Guard KCM165x when the monitored line voltage is higher than 690VAC. These adapters are a passive low-pass filter for use in 50, 60 or 400Hz networks, and is potted in polyurethane.

These units includes high inductance reactance modules, connected in a special configuration to avoid DC saturation. These Adapters maintains a high AC suppression of its signal output to very low, safe levels, under all conditions.

Caution

Terminal 1 must be disconnected during "megger" test.



AR7 up to 7kVAC

AR14 up to 14kVAC

AN7 up to 7kVAC

AN14 up to 14kVAC

AN25 up to 25kVAC

The MEGAICON policy is one of continuous improvement, consequently equipment supplied may vary in detail from this publication.



Connection

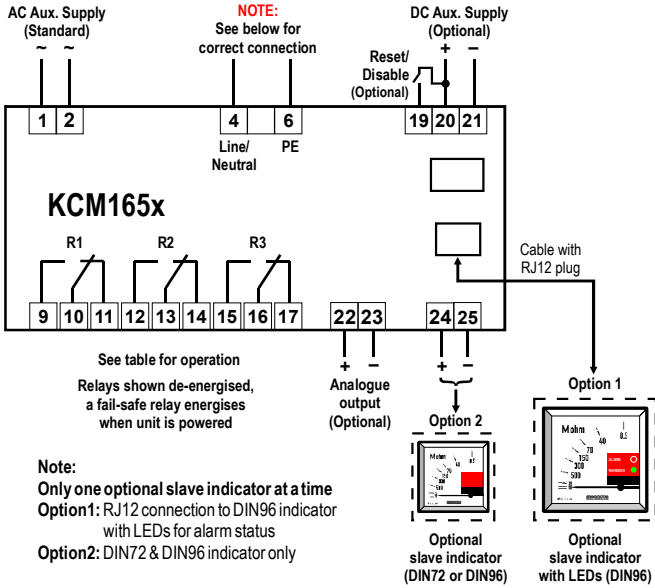

Analogue Output

KCM165HF, KCM165HGF, KCM165GF1, KCM165LF1, KCM165F1 and KCM165NF1 have an analogue output proportional to meter reading. (Special outputs are available on request)

Add suffix from table below to type designation to specify output required:

O/P1	0 - 10mA	O/P6	N/A
O/P2	0 - 20mA	O/P7	N/A
O/P3	4 - 20mA	O/P8	0 - 10VDC
O/P4	N/A	O/P9	N/A
O/P5	N/A	O/P10	N/A

Reset / Paralleling Disable Function

KCM165x has a built-in disable function. When connecting two or more IT-networks together **only one unit** can be active, the other(s) must be disabled. When unit is disabled the power led will flash every 2 seconds to indicate that unit is inactive.

Use a potential free contact on terminal 19 & 20 to activate the disable function (after 2 secs). When activated the measuring input terminal 4 will be internally disconnected.

A pulse (60mS - 2 secs) on terminal 19 & 20 will only reset any latching alarm.

Connection

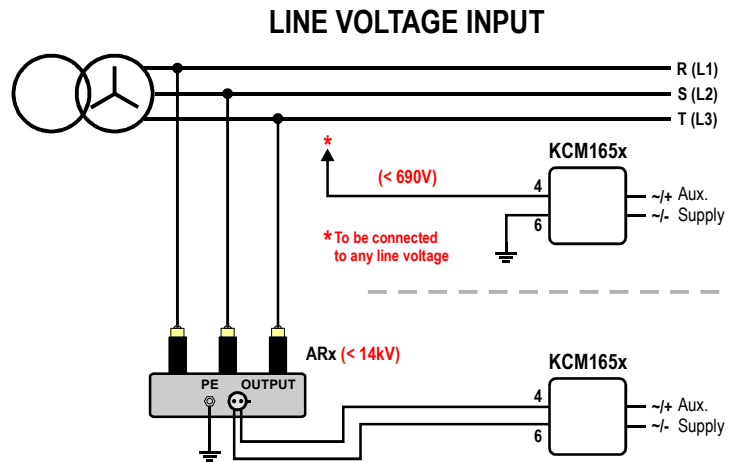
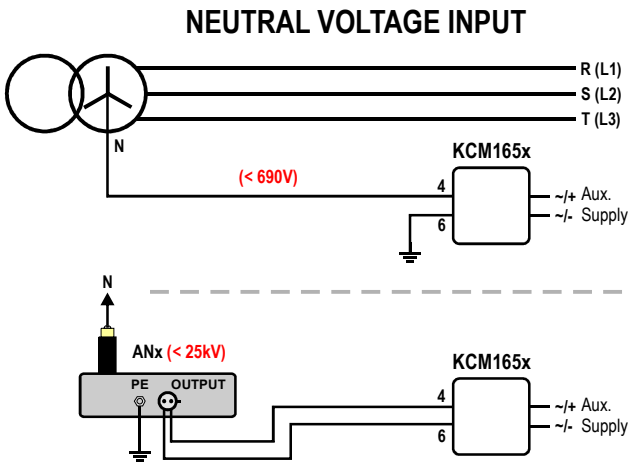

! The instrument will detect earth fault on all phases independent of which phase is connected to terminal 4.

Dimensions

Dimensions for Slave instrument

	DIN 72	DIN96
A	72 x 72mm	96 X 96mm
B	68 x 68mm	92 x 92mm
C	64mm	64mm

The MEGACON policy is one of continuous improvement, consequently equipment supplied may vary in detail from this publication.

ORDERING EXAMPLE:

Type: KCM165F1
 Aux. Supply: 200-240VAC
 Network Voltage: 14kVAC
 Analogue O/P: (O/P3) 4-20mA
 Range: 15Mohm - 10Gohm

