



- Direct connection up to 690V line voltage, up to 25kV with HV adapter for both single or three phase systems, continuous standby monitoring for motors, pumps etc.
- For use in land, marine, offshore installations
- Complies with IMCA D 045 Code of Practice
- "Megger" - safe to 1.4kVDC when aux power is OFF
- Paralleling Disable Function
- Triple-zone insulation monitoring
- Immune to earth capacitance
- Analogue output proportional to meter reading
- Optional slave indicator

## Specifications

Auxiliary Supply:	100-120, 200-240, 380-415 or 440-460VAC, 40-70Hz (Fuse 0.5A)
Optional Voltage:	12-24, 48 or 110VDC (Fuse 2A)
Supply tolerance:	± 10%
Power rating:	1,5VA
Contact rating:	AC: 100VA - 250V/2A max. DC: 50W - 100V/1A max.
Analogue Output:	Up to 20mA, max 500R
F-versions	Up to 10V, min 100kohm (other on request)
Temperature:	-20 to +70°C
Weight:	0.6kgs
Front protection:	IP21

### INTELLIGENT SETTING ASSISTANCE

KCM165K has a built-in Assistance tool for setting/verification of the trip levels and the analogue output.

When either the **Warning** or **Alarm** potmeter on the front is operated by user, the slave meter goes into **Assistance Mode** and meter reading and analogue output will reflect the potmeter setting.

#### How to set alarm levels:

Firstly adjust potmeter fully clockwise (see that meter goes to the top), then adjust potmeter down to required **Warning** or **Alarm** setpoint. In this mode, the Alarm or Warning LEDs (depending on which potmeter is adjusted) will flash quickly Red/Yellow.



Without any movement of potmeters, the meter will revert to normal Insulation Monitoring Mode after approximately 10 seconds.

#### How to test analogue output signal:

Adjust any trip level potmeter to activate Assistance Mode. **Example:** On a 4-20mA output, adjust potmeter fully anti clockwise for 4mA and fully clockwise for 20mA.

The KCM165K range is designed to comply with specification IMCAD 045 "Code of Practice for the Safe Use of Electricity Under Water" issued by IMCA.

The unit meets IEC60092-504 and the relevant environmental and EMC tests specified in IEC60068/60092 and IEC61000/60533 respectively, to comply with the requirements of the major Classification Societies.

## Application

The digitally controlled KCM165K monitors insulation level between a non-live non-grounded (IT) AC system and its protective earth. This unit is used for marine, offshore, seabed and down hole installations for meggering in standby position.

An AC or DC auxiliary voltage is required for the unit. Only **ONE** KCM16K can be connected to each IT-system. The ohmmeter and the triple-zone status LEDs give at a glance the clear safety message:

- ALARM (red zone)
- WARNING (yellow zone)
- HEALTHY (green zone)



## General

### IDV MEASURING PRINCIPLE

Insulation is measured between the complete galvanically interconnected AC network and its protective earth.

The unit injects a 15VDC measuring signal into the monitored system. The signal flows to ground via the path of the insulation fault, the level of flow indicates the insulation resistance. The measuring accuracy is not influenced by any normal kind of load attached to the AC network. The KPM165K measures all phases just by connection to either line or neutral point.

Start of monitoring function is delayed when auxiliary power is switched on (default 30 secs delay) to avoid false reading caused by initial charging of network spread capacitance. If powered from separate source there can be a stabilizing time if there is network spread capacitance.

### MEGGER SAFE

When auxiliary power is **OFF** the unit input is automatically protected against "megger" test voltages up to 1.4kVDC, and incorrect measurements caused by the unit's input impedance are avoided.

### OUTPUTS

The unit has C/O relay outputs for Warning and Alarm. The Alarm relays are fail to safety configured. A trip LED flashes when the trip level is passed, the relay trips when the delay has elapsed. The timer resets if the fault is removed during countdown. Trip levels and delays are settable on unit front.

The unit is supplied with an isolated **analogue output** proportional to insulation level. If output is used for remote meter reading, we recommend 0-1mA for the slave indicator.

### SAFETY

To protect the KCM165K and personnel against high voltage exposure a voltage adapter is needed for line-voltage above 690V.

## Analogue Output

The analogue output proportional to meter reading. Output diagram/table shows the values for a 4-20mA signal. (Special outputs are available on request)

Add suffix from table below to type designation to specify output required:

O/P1	<b>0 - 10mA</b>	O/P6	N/A
O/P2	<b>0 - 20mA</b>	O/P7	N/A
O/P3	<b>4 - 20mA</b>	O/P8	N/A
O/P4	N/A	O/P9	N/A
O/P5	N/A	O/P10	N/A

## Output diagram

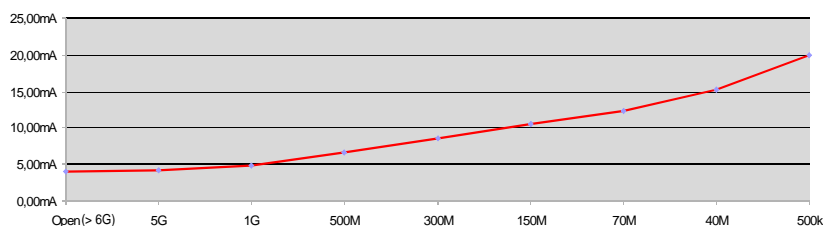

## Relay Operation

Scale range: 500kΩ-5GΩ - ∞ (>6GΩ)

	Warning	Alarm	Fail Safe	Latch
R1	✓			
R2		✓	✓	✓
R3		✓	✓	✓

<b>Model</b>	<b>Latch</b>	<b>Output</b>	<b>Adjustments</b>	<b>Trip level</b>	<b>Delay</b>
KCM165K	X	X	WARNING: 500kΩ-3GΩ ALARM: 500kΩ-3GΩ	500kΩ-3GΩ	0-30secs 0-30secs

Coloured sectors show recommended areas of settings:  
■ - Indicates alarm trip zone  
■ - Indicates warning trip zone  
■ - Indicates healthy zone

## Output table (example for 4-20mA) Range (slave indicator)

Value (scale)	mA output
500kΩ	20.00mA
40MΩ	15.18mA
70MΩ	12.28mA
150MΩ	10.57mA
300MΩ	8.63mA
500MΩ	6.64mA
1GΩ	4.93mA
5GΩ	4.20mA
Open (>6GΩ)	4.00mA

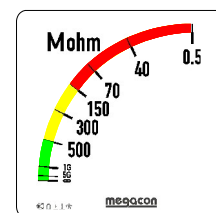

## HV Adaptors for voltages from 750 to 25kV



CH163/1,4 up to 1.4kVAC



CH163/3,6 up to 3.6kVAC



CH163/5 up to 5kVAC



AN6,6 up to 6,6kVAC



AN7 up to 7kVAC



AN14 up to 14kVAC

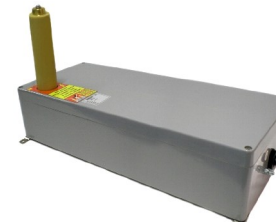

AN25 up to 25kVAC

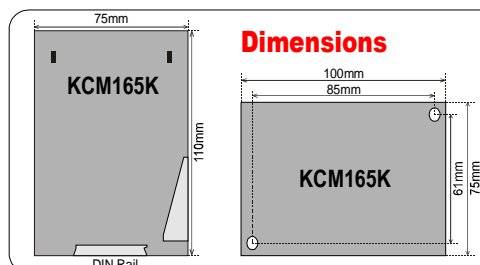

### Dimensions for Slave instrument

	DIN 72	DIN96
A	72 x 72mm	96 X 96mm
B	68 x 68mm	92 x 92mm
C	64mm	64mm

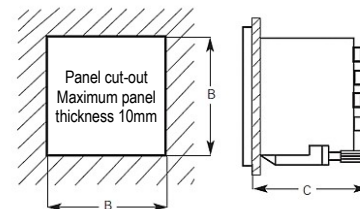
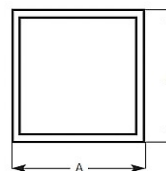

The MEGACon policy is one of continuous improvement, consequently equipment supplied may vary in detail from this publication.



## Connection

### Reset / Paralleling Disable Function

KCM165K has a built-in disable function. When connecting two or more IT-networks together **only one unit** can be active, the other(s) must be disabled.

When unit is disabled the power LED will flash every 2 seconds to indicate that unit is inactive.

Use a potential free contact on terminal 19 & 20 to activate the disable function (after 2 secs). When activated the measuring input terminal 4 will be internally disconnected.

A pulse (60mS - 2 secs) on terminal 19 & 20 will only reset any latching alarm.

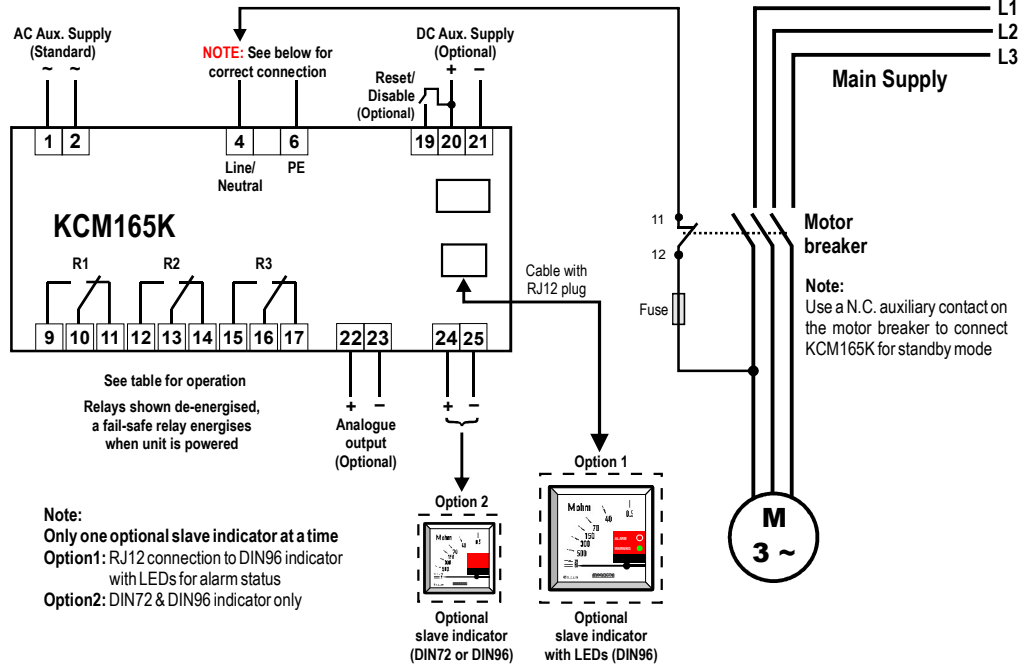

## Connection

### LINE VOLTAGE INPUT

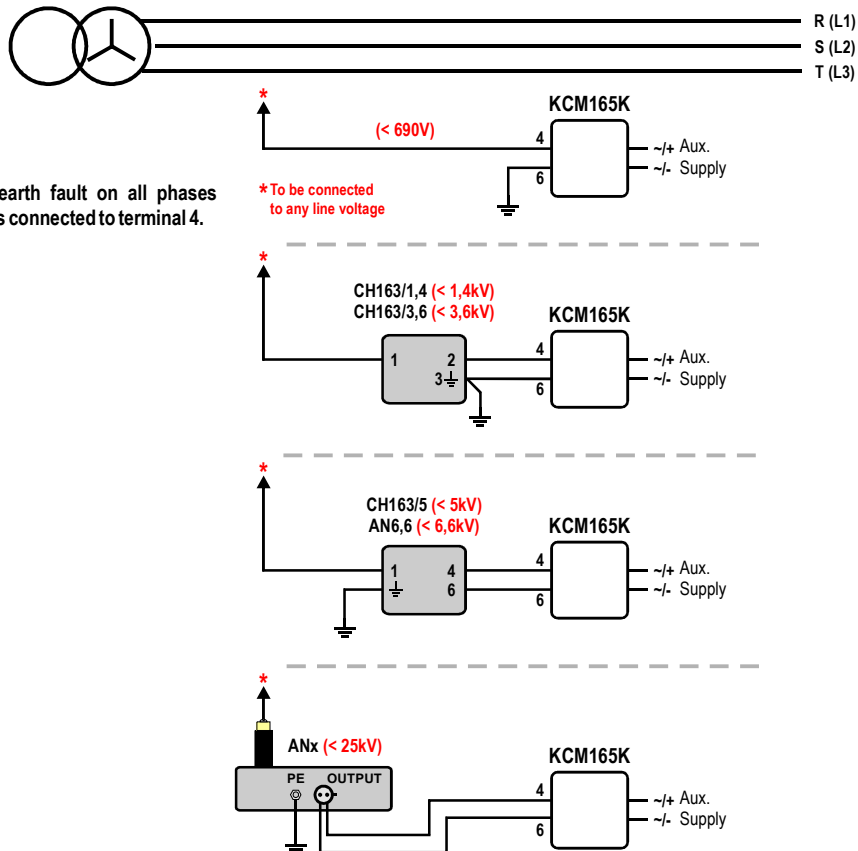

! The instrument will detect earth fault on all phases independent of which phase is connected to terminal 4.

The MEGACON policy is one of continuous improvement, consequently equipment supplied may vary in detail from this publication.

#### ORDERING EXAMPLE:

Type: KCM165K  
 Aux. Supply: 24VDC  
 Network Voltage: 690V  
 Analogue O/P: (O/P3) 4-20mA

