



Energy Division

Crompton Instruments Ebony Current Transformers

Moulded Case Current Transformers

Ebony Series Measuring and Protection

The range of Crompton Instruments Ebony current transformers offers wide system current ratings, apertures, busbar and case sizes to suit every application. Manufactured to meet IEC 60044-1:2003 the range benefits include ratio rating from 1/5 to 6000/5, accuracy up to class 0.5, integral terminal cover for safety and multiple mounting options.

Construction

The toroidal core and secondary winding is encapsulated by a self-extinguishing polycarbonate moulded case cover providing excellent mechanical strength and electrical insulation. The material is halogen free thus reducing risk of halogen emissions in case of fire. The integral covered secondary terminals offer protection to IP20B and the enclosure is protected to IP40.

Installation options

- Plug in metal feet for wall or base mounting
- Plastic DIN-rail clips for DIN-rail mounting
- Moulded busbar mounting
- Primary copper busbar mounting
- Multi busbar mounting for two busbars

Specifications

Active energy accuracy:	Class 1 in accordance with CEI-EN 62053-21 standard
System voltage:	720V maximum
Test voltage:	3kV for 1 minute
System frequency:	50/60Hz
Short circuit thermal current (I _{th}):	60 x rated primary current for 1 second
Overload withstand:	1.2 x rated current continuously
Dynamic current (I _{dyn}):	= 2.55 x I _{th}
Saturation coefficient:	<5 for through aperture models <10 for wound primary
Service temperature:	-20°C to 85°C
Insulation class:	Class E
BS2757 IEC85:	
Enclosure code:	IP40
Integral terminal cover:	IP20B
Complies with:	IEC 60044-1:2003
Humidity:	Up to 95% RH (non condensing)
Secondary terminals screw clamp:	Up to 10mm ² cable
'Fast On':	6.3mm type

Loss in copper wires between instrument and CT for 5A secondary

Wire Section in mm ²	Loss in VA (for both wires)					
	1m	2m	4m	6m	8m	10m
1.5	0.60	1.19	2.38	3.57	4.76	5.95
2.5	0.36	0.71	1.43	2.14	2.86	3.57
4	0.22	0.45	0.89	1.34	1.79	2.23
6	0.15	0.30	0.60	0.89	1.19	1.49
10	0.09	0.18	0.36	0.54	0.71	0.89

Loss in copper wires between instrument and CT for 1A secondary

Wire Section in mm ²	Loss in VA (for both wires)					
	10m	20m	40m	60m	80m	100m
1	0.36	0.71	1.43	2.14	2.86	3.57
1.5	0.24	0.48	0.95	1.43	1.90	2.38
2.5	0.14	0.29	0.57	0.86	1.14	1.43
4	0.09	0.18	0.36	0.54	0.71	0.89
6	0.06	0.12	0.24	0.36	0.48	0.60
10	0.04	0.07	0.14	0.21	0.29	0.36

Consult factory for availability and lead time on 1A secondary.



Features

- CT ratios from 1/5 to 6000/5
- Accuracy up to Class 0.5
- Integral terminal cover
- High impact, flame retardant moulded case
- Busbar, DIN-rail or foot mounting options

Benefits

- Wide range of apertures and case sizes
- Reduction of high currents for ease of metering
- Long product life

Approvals

- 2006/95/EC
- BS EN 61010-1
- EC 60044-1
- UL Recognized file no: E257877 (MA5Y, M55E, M53J, M63N, M93L, MB5D, MB5Z only)

* Thermal Current (I_{th}) & Dynamic Current (I_{dyn})

I_{th} is the highest primary current (effective value), the I_{dyn} is the highest primary current (Peak Value) that the C.T. can support for 1 second without damage, owing to excessive overloads with secondary short circuits.

M53Q Range

Case Size: 45mm wide x 30mm deep x 65mm high
 1.8" wide x 1.2" deep x 2.5" high
 Aperture: 20 x 6mm and 21mm diameter
 0.8" x 0.2" and 0.8" diameter
 Weight: 0.25kg

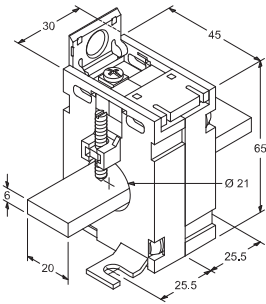

- Mounting feet centres 26mm x 51mm

Model type	Ratio range	VA at Class 3	VA at Class 1
M53Q	50/5	1	-
M53Q	60/5	1.25	-
M53Q	75/5	1.5	-
M53Q	80/5	1.5	-
M53Q	100/5	2.5	1.5
M53Q	125/5	3	2.5
M53Q	150/5	3.75	2.5
M53Q	200/5	5	3.75
M53Q	250/5	-	5
M53Q	300/5	7.5	5

Ordering Codes

M53Q	Add suffix to depict required ratio range. For example: M53Q-50/5
M30-DINCLIP	DIN-rail mounting clip for DIN-rail mounting option (2 required)

M55E Range

Case Size: 50mm wide x 50mm deep x 80mm high
 2" wide x 2" deep x 3.1" high
 Aperture: 15 x 5mm and 16 diameter
 0.6" x 0.2" diameter
 Weight: 0.4Kg

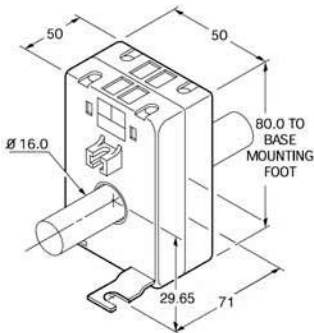

- Mounting feet centres 33mm x 71mm

Model type	Ratio range	VA at Class 3	VA at Class 1
M55E	30/5	1.25	-
M55E	40/5	2.5	-
M55E	50/5	2.5	-
M55E	60/5	3.75	2.5
M55E	75/5	5	3.75
M55E	80/5	5	3.75
M55E	100/5	7.5	5

Ordering Codes

M55E	Add suffix to depict required ratio range. For example: M55E-60/5
M50-DINCLIP	DIN-rail mounting clip for DIN-rail mounting option (2 required)

M53J Range

Case Size: 50mm wide x 30mm deep x 80mm high
 2" wide x 1.2" deep x 3.1" high
 Aperture: 30 x 10mm, 25 x 15mm and 20 x 20mm and 25mm diameter
 1.2" x 0.4", 1" x 0.6" and 0.8" x 0.8" and 1.0" diameter
 Weight: 0.22Kg

Model type	Ratio range	VA at Class 3	VA at Class 1
M53J	100/5	1.25	-
M53J	125/5	1.25	-
M53J	150/5	2.5	-
M53J	160/5	2.5	-
M53J	200/5	2.5	2.5
M53J	250/5	3.75	2.5
M53J	300/5	5	3.75
M53J	400/5	7.5	3.75

Ordering Codes

M53J	Add suffix to depict required ratio range. For example: M53J-100/5
M30-DINCLIP	DIN-rail mounting clip for DIN-rail mounting option (2 required)

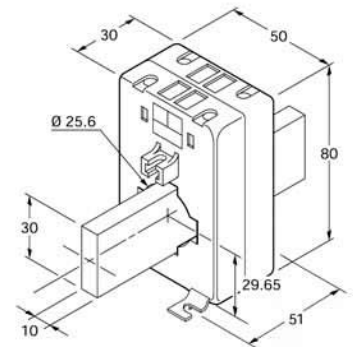

- Mounting feet centres 33mm x 51mm

M65F Range

Case Size: 60mm wide x 50mm deep x 94mm high
 2.4" wide x 2" deep x 3.7" high
 Aperture: 20 x 10mm and 23mm diameter
 0.8" x 0.4", 0.9" diameter
 Weight: 0.4Kg

Model type	Ratio range	VA at Class 3	VA at Class 1	VA at Class 0.5
M65F	30/5	1.25	-	-
M65F	40/5	2.5	-	-
M65F	50/5	2.5	-	-
M65F	60/5	3.75	-	-
M65F	75/5	5	2.5	-
M65F	80/5	5	2.5	-
M65F	100/5	7.5	5	2.5
M65F	125/5	7.5	5	2.5
M65F	150/5	15	10	5
M65F	200/5	20	15	7.5
M65F	250/5	20	20	10
M65F	300/5	30	30	10

Ordering Codes

M65F	Add suffix to depict required ratio range. For example: M65F-30/5
M50-DINCLIP	DIN-rail mounting clip for DIN-rail mounting option (2 required)

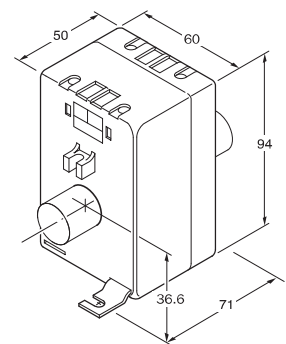

- Mounting feet centres 42mm x 71mm

M63N Range

Case Size: 60mm wide x 30mm deep x 94mm high
 2.3" wide x 1.2" deep x 3.7" high
 Aperture: 40 x 10mm and 32mm diameter
 1.5" x 0.4" and 1.2" diameter
 Weight: 0.3Kg

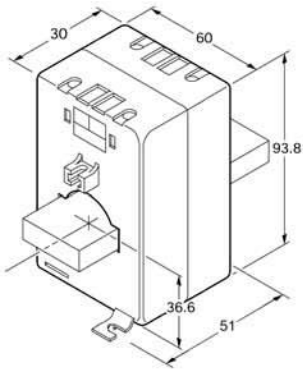

- Mounting feet centres 42mm x 51mm

Model type	Ratio range	VA at Class 3	VA at Class 1	VA at Class 0.5
M63N	200/5	2.5	-	-
M63N	250/5	3.75	2.5	-
M63N	300/5	5	3.75	-
M63N	400/5	7.5	5	-
M63N	500/5	10	7.5	3.75
M63N	600/5	10	7.5	5
M63N	750/5	15	10	7.5
M63N	800/5	15	10	7.5

Ordering Codes

M63N	Add suffix to depict required ratio range. For example: M63N-200/5
M30-DINCLIP	DIN-rail mounting clip for DIN-rail mounting option (2 required)

MA5G Range

Case Size: 77mm wide x 50mm deep x 116mm high
 3" wide x 2" deep x 4.5" high
 Aperture: 40 x 10mm, 30 x 30mm and 36mm diameter
 1.6" x 0.4", 1.2" x 1.2" and 1.4" diameter
 Weight: 0.6Kg

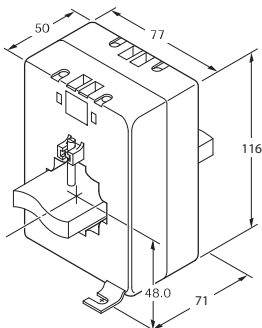

- Mounting feet centres 58.5mm x 71mm

Model type	Ratio range	VA at Class 3	VA at Class 1	VA at Class 0.5
MA5G	100/5	2.5	-	-
MA5G	125/5	5	2.5	-
MA5G	150/5	5	3.75	-
MA5G	200/5	10	5	2.5
MA5G	250/5	10	7.5	5
MA5G	300/5	10	7.5	5
MA5G	400/5	10	7.5	5
MA5G	500/5	10	7.5	5
MA5G	600/5	10	10	7.5
MA5G	750/5	15	10	10
MA5G	800/5	15	10	10
MA5G	1000/5	20	15	15

Ordering Codes

MA5G	Add suffix to depict required ratio range. For example: MA5G-100/5
M50-DINCLIP	DIN-rail mounting clip for DIN-rail mounting option (2 required)

MA5Y Range

Case Size: 77mm wide x 50mm deep x 116mm high
 3" wide x 2" deep x 4.5" high

Fixing: M8 stud primary bar
 Weight: 0.45Kg

Model type	Ratio range	VA at Class 3	VA at Class 1
MA5Y	1/5	7.5	5
MA5Y	5/5	7.5	5
MA5Y	10/5	7.5	5
MA5Y	15/5	7.5	5
MA5Y	20/5	7.5	5
MA5Y	30/5	7.5	5
MA5Y	40/5	7.5	5

Ordering Codes

MA5Y	Add suffix to depict required ratio range. For example: MA5Y-5/5
M50-DINCLIP	DIN-rail mounting clip for DIN-rail mounting option (2 required)

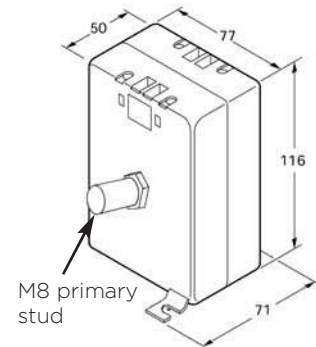

- Mounting feet centres 58.5mm x 71mm

M93L Range

Case Size: 90mm wide x 30mm deep x 131mm high
 3.5" wide x 1.2" deep x 5.1" high
 Aperture: 50 x 10mm, 40 x 30mm and 32mm diameter
 2" x 0.4", 1.5" x 1.2" and 1.3" diameter

Weight: 0.45Kg

Model type	Ratio range	VA at Class 3	VA at Class 1	VA at Class 0.5
M93L	400/5	15	7.5	3.75
M93L	500/5	20	15	5
M93L	600/5	30	20	10
M93L	750/5	20	15	7.5
M93L	800/5	20	15	10
M93L	1000/5	20	20	15
M93L	1200/5	30	30	20
M93L	1250/5	30	30	20
M93L	1500/5	30	30	20
M93L	1600/5	30	30	20

Ordering Codes

M93L	Add suffix to depict required ratio range. For example: M93L-400/5
M30-DINCLIP	DIN-rail mounting clip for DIN-rail mounting option (2 required)

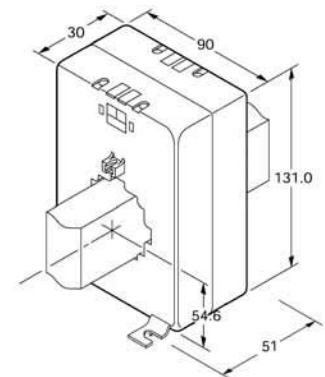

- Mounting feet centres 71.5mm x 51mm

M93R Range

Case Size: 90mm wide x 30mm deep x 131mm high
 3.5" wide x 1.2" deep x 5.1" high
 Aperture: 64 x 12.6mm, 60 x 30mm
 2.5" x 0.5", 2.4" x 1.2"
 Weight: 0.6Kg

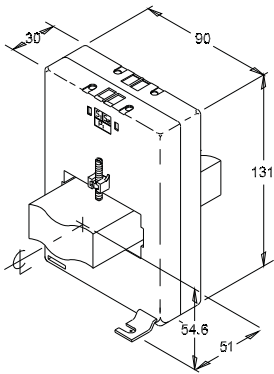

- Mounting feet centres
71.5mm x 51mm

Model type	Ratio range	VA at Class 3	VA at Class 1	VA at Class 0.5
M93R	800/5	10	10	5
M93R	1000/5	15	10	7.5
M93R	1200/5	20	15	10
M93R	1250/5	20	15	10
M93R	1500/5	20	20	15
M93R	1600/5	20	20	15
M93R	2000/5	30	20	20

Ordering Codes

M93R	Add suffix to depict required ratio range. For example: M93R-800/5
M30-DINCLIP	DIN-rail mounting clip for DIN-rail mounting option (2 required)

M93S Range

Case Size: 90mm wide x 30mm deep x 131mm high
 3.5" wide x 1.2" deep x 5.1" high
 Aperture: 76.5 x 19mm, 60 x 30mm
 3.0" x 0.7", 2.4" x 1.2"
 Weight: 0.7Kg

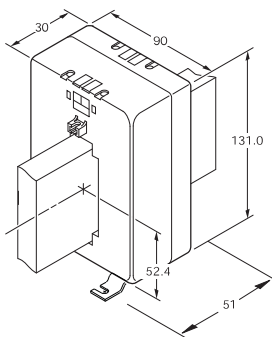

- Mounting feet centres
71.5mm x 51mm

Model type	Ratio range	VA at Class 3	VA at Class 1	VA at Class 0.5
M93S	800/5A	10	10	5
M93S	1000/5A	15	10	7.5
M93S	1200/5A	20	15	10
M93S	1250/5A	20	20	15
M93S	1500/5A	20	20	15
M93S	1600/5A	30	20	15
M93S	2000/5	30	20	15

Ordering Codes

M93S	Add suffix to depict required ratio range. For example: M93S-800/5
M30-DINCLIP	DIN-rail mounting clip for DIN-rail mounting option (2 required)

S95P Range

Case Size: 90mm wide x 50mm deep x 144mm high
 3.5" wide x 2" deep x 5.7" high
 Weight: 0.9Kg - 1.11Kg

Model type	Primary Current	VA at Class 1
S95P	5 + 5 = 5	5
S95P	5 + 5 + 5 = 5	5

Ordering Codes

S95P	Add suffix to depict required ratio range. For example: S95P-5/5
M50-DINCLIP	DIN-rail mounting clip for DIN-rail mounting option (2 required)

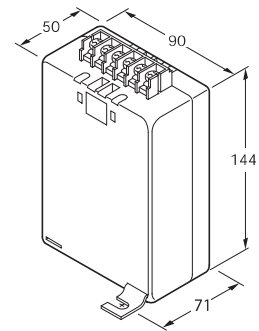

- Mounting feet centres 71.5mm x 71mm

S97P Range

Case Size: 90mm wide x 70mm deep x 144mm high
 3.5" wide x 2.8" deep x 5.6" high
 Weight: 1.3Kg - 1.5Kg

Model type	Primary Current	VA at Class 1
S97P	5 + 5 + 5 + 5 = 5	5
S97P	5 + 5 + 5 + 5 + 5 = 5	5
S97P	5 + 5 + 5 + 5 + 5 + 5 = 5	5

Ordering Codes

S97P	Add suffix to depict required ratio range. For example: S97P-5/5/5/5
------	---

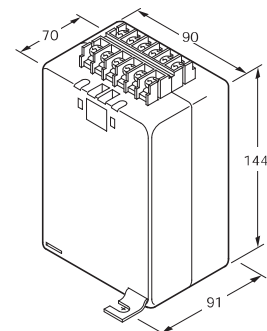

- Mounting feet centres 71.5mm x 91mm

MB5D Range



Case Size: 134mm wide x 50mm deep x 156mm high
 5.2" wide x 2" deep x 6.1" high
 Aperture: 80 x 30mm, 60 x 30mm, 50 X 50mm and 63mm diameter
 3.1" x 1.2", 2.3" x 1.2", 2 x 2" and 2.4" diameter
 Weight: 0.5Kg

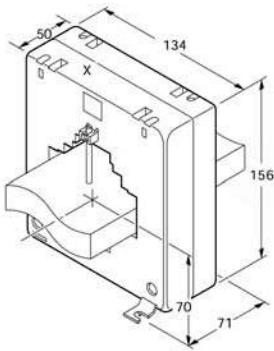

- Mounting feet centres 105mm x 71mm
- Mounting hole centres 110 x 6.6mm diameter

Model type	Ratio range	VA at Class 3	VA at Class 1	VA at Class 0.5
MB5D	400/5	15	10	7.5
MB5D	500/5	20	15	10
MB5D	600/5	15	10	5
MB5D	750/5	15	10	5
MB5D	800/5	20	15	7.5
MB5D	1000/5	22.5	20	10
MB5D	1200/5	30	20	15
MB5D	1250/5	30	20	15
MB5D	1500/5	30	20	15
MB5D	1600/5	40	30	20
MB5D	2000/5	50	40	30

Ordering Codes

MB5D Add suffix to depict required ratio range.
 For example: MB5D-400/5

MB5Z Range

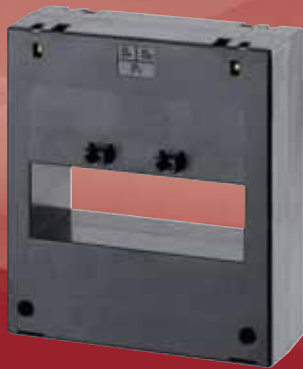

Case Size: 134mm wide x 50mm deep x 156mm high
 5.2" wide x 2" deep x 6.1" high
 Aperture: 104 x 35mm, 35mm diameter
 4" x 1.3" and 1.3" diameter
 Weight: 0.7Kg

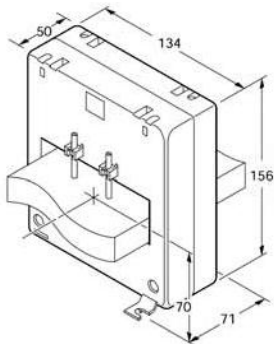

- Mounting feet centres 105mm x 71mm
- Mounting hole centres 110mm x 6.6mm diameter

Model type	Ratio range	VA at Class 3	VA at Class 1	VA at Class 0.5
MB5Z	750/5	15	7.5	2.5
MB5Z	800/5	20	10	2.5
MB5Z	1000/5	22.5	15	7.5
MB5Z	1200/5	30	20	10
MB5Z	1250/5	30	20	15
MB5Z	1500/5	30	20	15
MB5Z	1600/5	30	20	15
MB5Z	2000/5	30	20	15
MB5Z	2400/5	30	20	15
MB5Z	2500/5	30	20	15
MB5Z	3000/5	30	20	15
MB5Z	4000/5	30	20	15

Ordering Codes

MB5Z Add suffix to depict required ratio range.
 For example: MB5Z-750/5

MC5T Range

Case Size: 140mm wide x 50mm deep x 238mm high
 5.5" wide x 2" deep x 9.3" high
 Aperture: 160 x 50mm
 6.3" x 2"
 Weight: +/-1.5Kg

Model type	Ratio range	VA at Class 3	VA at Class 1	VA at Class 0.5
MC5T	1600/5	45	30	20
MC5T	2000/5	45	30	20
MC5T	2500/5	60	45	30
MC5T	3000/5	60	45	30
MC5T	3200/5	60	45	30
MC5T	4000/5	60	45	30
MC5T	5000/5	60	45	30
MC5T	6000/5	60	45	30

Ordering Codes

MC5T Add suffix to depict required ratio range.
 For example: MC5T-1600/5

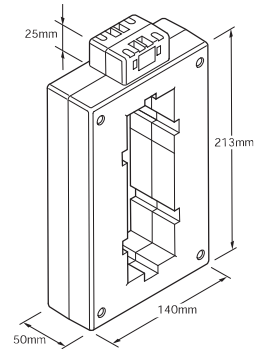

- Hole for M6 diameter screws or busbar mounting

MD5T Range

Case Size: 213mm wide x 50mm deep x 165mm high
 8.3" wide x 2" deep x 6.5" high
 Aperture: 160 x 50mm
 6.3" x 2"
 Weight: +/-1.5Kg

Model type	Ratio range	VA at Class 3	VA at Class 1	VA at Class 0.5
MD5T	1600/5	45	30	20
MD5T	2000/5	45	30	20
MD5T	2500/5	60	45	30
MD5T	3000/5	60	45	30
MD5T	4000/5	60	45	30
MD5T	5000/5	60	45	30
MD5T	6000/5	60	45	30

Ordering Codes

MD5T Add suffix to depict required ratio range.
 For example: MD5T-1600/5

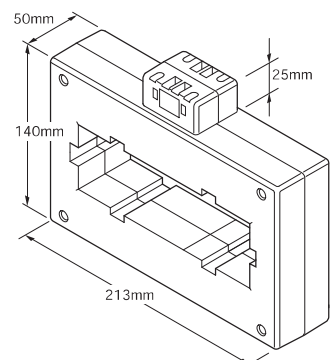
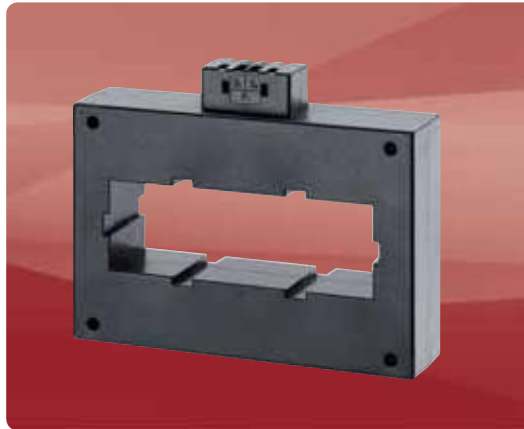

- Hole for M6 diameter screws or busbar mounting

Moulded Case Overview Range

Type	MA5Y		M53Q		M55E		M53J		M65F		M63N		MA5G		M93L	
Inside diameter (mm)			21		16.2		25		23		32		36		32	
Busbar	M8 Stud		20x6		15x5		30x10		20x10		40x10		40x10		50x10	
							25x15						30x30		40x30	
							20x20									
Dimensions (mm)																
H	116		65		80		80		94		94		116		131	
W	77		45		50		50		60		60		77		90	
D	50		30		50		50		50		30		50		30	
DIN-rail mounting	X	X	X	X	X	X	X	X	X	X	X	X	X	X	X	X
Foot mounting	X	X	X	X	X	X	X	X	X	X	X	X	X	X	X	X
Intergrated terminal cover	X	X	X	X	X	X	X	X	X	X	X	X	X	X	X	X
Secondary	5	1	5	1	5	1	5	1	5	1	5	1	5	1	5	1
Primary current																
1	X	X														
5	X	X														
10	X	X														
15	X	X														
20	X	X			X	X										
30	X	X			X	X			X	X						
40	X	X			X	X			X	X						
50			X	X	X	X			X	X						
60			X	X	X	X			X	X						
75			X	X	X	X			X	X						
80			X	X	X	X			X	X						
100			X	X	X	X	X		X	X			X	X		
125			X	X			X		X	X			X	X		
150			X	X			X		X	X			X	X		
160							X									
200			X	X			X		X	X	X	X	X	X		
250			X	X			X		X	X	X	X	X	X		
300			X	X			X		X	X	X	X	X	X		
400							X				X	X	X	X	X	
500											X	X	X	X	X	
600											X	X	X	X	X	
750											X	X	X	X	X	
800											X	X	X	X	X	
1000													X	X	X	
1200															X	
1250																
1500																X
1600																X
2000																
2500																
3000																
3200																
4000																
5000																
6000																
5 + 5 = 5																
5 + 5 + 5 = 5																
5 + 5 + 5 + 5 = 5																
5 + 5 + 5 + 5 + 5 = 5																
5 + 5 + 5 + 5 + 5 + 5 = 5																
1 + 1 = 1																
1 + 1 + 1 = 1																
1 + 1 + 1 + 1 = 1																
1 + 1 + 1 + 1 + 1 = 1																
1 + 1 + 1 + 1 + 1 + 1 = 1																

Type	M93S		M93R		MB5D		MB5Z		MCST		MD5T		S95		S97	
Inside diameter (mm)					63		35									
Busbar	60x30		60x30		80x30		104x35		50x160		160x50					
	76.5x19		64x12.6		60x30											
					50x50											
Dimensions (mm)																
H	131		131		156		156		238		165		144		144	
W	90		90		134		134		140		213		90		90	
D	30		30		50		50		50		50		50		70	
DIN-rail mounting	X	X	X	X									X	X		
Foot mounting	X	X	X	X	X	X	X	X					X	X	X	X
Intergrated terminal cover	X	X	X	X	X	X	X	X	X	X	X					
Secondary	5	1	5	1	5	1	5	1	5	1	5	1	5	1	5	1
Primary current																
5																
10																
15																
20																
25																
30																
40																
50																
60																
75																
80																
100																
125																
150																
160																
200																
250																
300																
400					X	X										
500					X	X										
600					X	X										
750					X	X	X	X								
800	X	X	X	X	X	X	X	X								
1000	X	X	X	X	X	X	X	X								
1200	X	X	X	X	X	X	X	X								
1250	X	X	X	X	X	X	X	X								
1500	X	X	X	X	X	X	X	X								
1600	X	X	X	X	X	X	X	X	X	X	X	X				
2000	X	X	X	X	X	X	X	X	X	X	X	X				
2500							X	X	X	X	X	X				
3000							X	X	X	X	X	X				
4000							X	X	X	X	X	X				
5000									X		X					
6000									X		X					
5 + 5 = 5													X			
5 + 5 + 5 = 5													X			
5 + 5 + 5 + 5 = 5															X	
5 + 5 + 5 + 5 + 5 = 5															X	
5 + 5 + 5 + 5 + 5 + 5 = 5															X	
1 + 1 = 1														X		
1 + 1 + 1 = 1														X		
1 + 1 + 1 + 1 = 1																X
1 + 1 + 1 + 1 + 1 = 1																X
1 + 1 + 1 + 1 + 1 + 1 = 1																X

Energy Division

With 4000 employees and more than 10,000 customers world-wide, the Energy Division represents a very significant part of Tyco Electronics. Based in headquarters in Ottobrunn, near Munich, Germany, the Energy Division is a global supplier to power utilities and power industry customers, to equipment manufacturers and transport systems. These customers are served by dedicated R&D teams, sales representatives in more than 80 countries, a professional marketing organization and 25 manufacturing sites in five continents.

While Tyco Electronics and its affiliates referenced herein have made every reasonable effort to ensure the accuracy of the information contained in this catalogue, Tyco Electronics cannot assure that this information is error free. For this reason, Tyco Electronics does not make any representation or offer any guarantee that such information is accurate, correct, reliable or current. Tyco Electronics reserves the right to make any adjustments to the information at any time. Tyco Electronics expressly disclaims any implied warranty regarding the information contained herein, including, but not limited to, the implied warranties of merchantability or fitness for a particular purpose. Tyco Electronics' only obligations are those stated in Tyco Electronics' Standard Terms and Conditions of Sale. Tyco Electronics will in no case be liable for any incidental, indirect or consequential damages arising from or in connection with, including, but not limited to, the sale, resale, use or misuse of its products. Users should rely on their own judgement to evaluate the suitability of a product for a certain purpose and test each product for its intended application. TE (logo) and Tyco Electronics are trademarks of the Tyco Electronics group of companies and its licensors. Crompton is a trademark of Crompton Parkinson and is used by Tyco Electronics under a licence. Other Trademarks mentioned herein are the property of their respective owners.

Energy Division – economical solutions for the electrical power industry: cable accessories, connectors & fittings, electrical equipment, instruments, lighting controls, insulators & insulation enhancement and surge arresters.

Tyco Electronics UK Ltd
Energy Division
Freebournes Road
Witham, Essex CM8 3AH

Phone: +44 (0)870 870 7500
Fax: +44 (0)870 240 5287
Email: electrical@tycoelectronics.com

www.crompton-instruments.com
<http://energy.tycoelectronics.com>



Our commitment. Your advantage.