



- Designed for non-grounded networks with Frequency Converters
- Direct connection up to 690V line voltage, up to 6,6kV with HV adapters for both single or three phase systems
- Monitoring during both live and standby conditions
- For use in land, marine and offshore Installations
- Complies with IMCA D 045 Code of Practice
- "Megger" - safe to 1.4kVDC when aux power is OFF
- Immune to earth capacitance and voltage surges
- Analogue output proportional to meter reading

## Specifications

Auxiliary Supply:	100-120, 200-240, 380-415 or 440-460VAC, 40-70Hz (Fuse 0.5A)
Optional Voltage:	12-24, 48 or 110VDC (Fuse 2A)
Supply tolerance:	± 10%
Power rating:	1,5VA
Contact rating:	AC: 100VA - 250V/2A max. DC: 50W - 100V/1A max.
Analogue Output:	Up to 20mA, max 500R
F-versions	Up to 10V, min 100kohm (other on request)
Temperature:	-20 to +70°C
Weight:	0.85kgs
Front protection:	IP52 (IP65 optional)

## Application

The digitally controlled KPM163FQx is designed to monitor the insulation level between a non-grounded (IT) AC mains and its protective earth in systems with frequency converters. The unit is for land, marine and offshore use.

An AC or DC auxiliary voltage is required for the unit, if powered from a separate source the network can also be monitored during inactive (standby) conditions. Only **ONE** KPM163FQx can be connected to each IT-system. The ohmmeter and the triple-zone status LEDs give at a glance the clear safety message:

- ALARM (red zone)
- WARNING (yellow zone)
- HEALTHY (green zone)

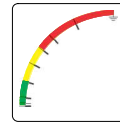

### INTELLIGENT SETTING ASSISTANCE

KPM163FQx has a built-in Assistance tool for setting/verification of the trip levels and the analogue output.

When either the **Warning** or **Alarm** potmeter on the rear is operated by user, the meter goes into **Assistance Mode** and meter reading and analogue output will reflect the potmeter setting.

#### How to set alarm levels:

Firstly adjust potmeter fully clockwise (see that meter goes to the top), then adjust potmeter down to required **Warning** or **Alarm** setpoint. In this mode, the Alarm or Warning LEDs (depending on which potmeter is adjusted) will flash quickly Red/Yellow.



Without any movement of potmeters, the meter will revert to normal Insulation Monitoring Mode after approximately 10 seconds.

#### How to test analogue output signal:

Adjust any trip level potmeter to activate Assistance Mode. **Example:** On a 4-20mA output, adjust potmeter fully anti clockwise for 4mA and fully clockwise for 20mA.

The KPM163FQx range is designed to comply with specification IMCA D 045 "Code of Practice for the Safe Use of Electricity Under Water" issued by IMCA.

The unit meets EN 61010-1 Cat. III, Pollution degree 2 and the relevant environmental and EMC tests specified in EN 61326-2-4 to comply with the requirements of the major Classification Societies.

## General

### IDV MEASURING PRINCIPLE

Insulation is measured between the complete galvanically interconnected AC network and its protective earth.

The unit injects a DC measuring signal into the monitored system. The signal flows to ground via the path of the insulation fault, the level of flow indicates the insulation resistance. The measuring accuracy is not influenced by any normal kind of load attached to the AC network.

This unit is used for any land, marine or offshore installations. Start of monitoring function is delayed when auxiliary power is switched on (default 10 secs delay). The unit has minimum of 9 seconds detection time for any insulation fault.

Trip levels and delays are settable on unit rear. A trip LED flashes when the trip level is passed, the relay trips when the delay has elapsed. The timer resets if the fault is removed during countdown.

### MEGGER SAFE

When auxiliary power is **OFF** the unit input is automatically protected against "megger" test voltages up to 1.4kVDC, and incorrect measurements caused by the unit's input impedance are avoided.

### OUTPUTS

The KPM163FQx has an isolated **analogue output** proportional to meter reading. If output is used for remote meter reading, we recommend 0-1mA for the slave indicator.

### SAFETY

When a voltage adapter (CHx or ANx) is used the signal to terminals 4 and 6 on KPM163FQx is limited to a safe level, avoiding any dangerous voltage exposure to personnel.

### HIGH VOLTAGE ADAPTOR

Voltage Adaptors CHx and ANx series are used for Insulation Guard KPM163FQx when the monitored line voltage is higher than 690VAC.

## Description

### KPM163FQ - KPM163FQG

This unit is used for industrial, marine and offshore installations with frequency converters. Start of monitoring function is delayed when auxiliary power is switched on (default 10 secs delay). The unit has a detection time of 6-9 seconds for any insulation fault.

Direct connection up to 690V line voltage. Up to 6,6kV via HV adaptors.

## Relay Operation

Scale range: 0-10MΩ - ∞ (>60MΩ)

Relay	Warning	Alarm	Fail Safe	Latch
R1	X			
R2		X	X	*X
R3		X		*X

Model	Latch	Output	Adjustments	Trip level	Delay
KPM163FQ	-	X	WARNING:	0-10MΩ	0-30secs
KPM163FQG*	X	X	ALARM:	0-10MΩ	0,1-3secs

Coloured sectors show recommended areas of settings:  
 - Indicates alarm trip zone  
 - Indicates warning trip zone  
 - Indicates healthy zone

## Output diagram

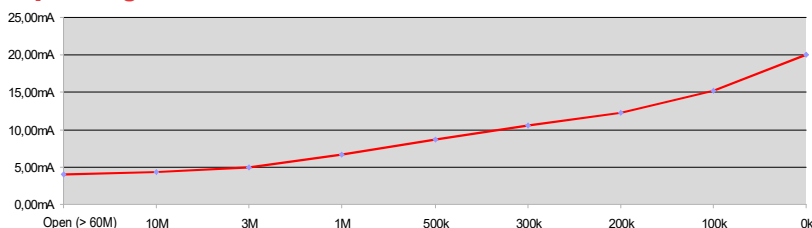

## Output table (example for 4-20mA)

Value (scale)	mA output
0kΩ	20.00mA
100kΩ	15.18mA
200kΩ	12.30mA
300kΩ	10.59mA
500kΩ	8.67mA
1000kΩ	6.69mA
3MΩ	4.98mA
10MΩ	4.28mA
Open (>60MΩ)	4.00mA

## Range (slave indicator)

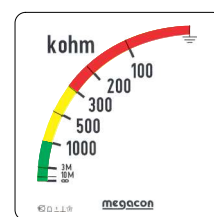

## High Voltage Adaptors up to 6,6kVAC for KPM163FQx series

- HV Adaptor for AC Insulation Guards
- CH163Bx series, up to 5000V Line Voltage live or non-live (standby)
- AN6,6B up to 6600V System Voltage live or non-live (Starpoint/Neutral connection only)
- Creates safety barrier from live HT network to LV switchboard
- Limits measuring output signal to safe levels
- No restrictions on distance between adapter and LV switchboard

Voltage Adaptors CH163Bx and AN6,6B series are used for Insulation Guard KPM163FQx when the monitored line voltage is higher than 690VAC. These adaptors are a passive low-pass filter for use in 50, 60 or 400Hz networks, and are potted in polyurethane.

These units includes high inductance reactance modules, connected in a special configuration to avoid DC saturation. These adaptors maintain a high AC suppression of its signal output to very low, safe levels, under all conditions.

### Caution

Terminal 1 must be disconnected during "megger" test.



CH163/1,4 up to 1.4kVAC



CH163B/3,6 up to 3.6kVAC



CH163B/5 up to 5kVAC



AN6,6B up to 6,6kVAC

The MEGAICON policy is one of continuous improvement, consequently equipment supplied may vary in detail from this publication.



## Connection

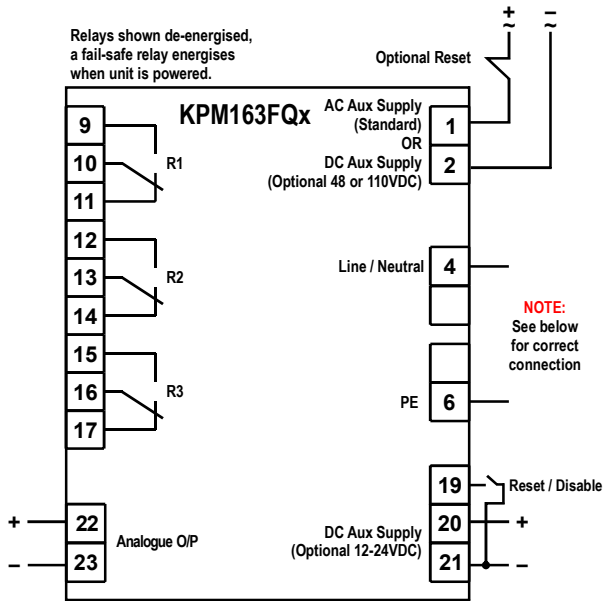

## Analogue Output

KPM163FQ and KPM163FQG have an analogue output proportional to meter reading. (Special outputs are available on request)

Add suffix from table below to type designation to specify output required:

O/P1	0 - 10mA	O/P6	N/A
O/P2	0 - 20mA	O/P7	N/A
O/P3	4 - 20mA	O/P8	0 - 10VDC
O/P4	N/A	O/P9	N/A
O/P5	N/A	O/P10	N/A

## Reset / Paralleling Disable Function

KPM163FQx has a built-in disable function. When connecting two or more IT-networks together **only one unit** can be active, the other(s) must be disabled. When unit is disabled the power led will flash every 2 seconds to indicate that unit is inactive.

Use a potential free contact on terminal 19 & 21 to activate the disable function (after 2 secs). When activated the measuring input terminal 4 will be internally disconnected.

A pulse (60mS - 2 secs) on terminal 19 & 21 will only reset any latching alarm.

## Connection NEUTRAL VOLTAGE INPUT

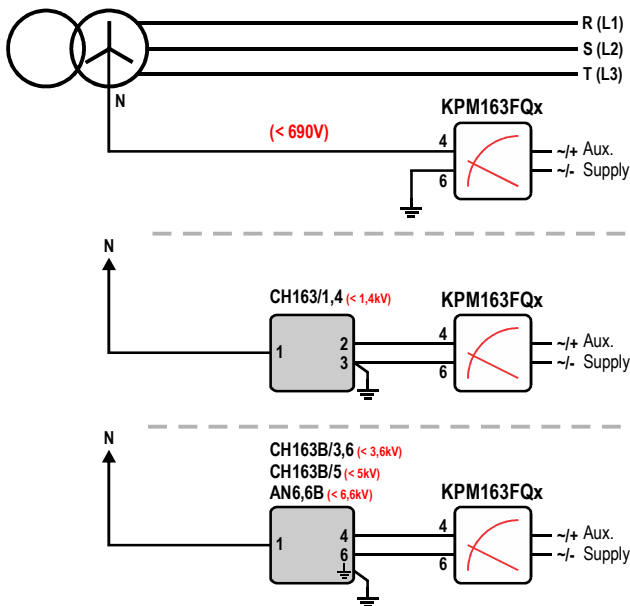

**!** The instrument will detect earth fault on all phases independent of which phase is connected to terminal 4.

## Connection LINE VOLTAGE INPUT

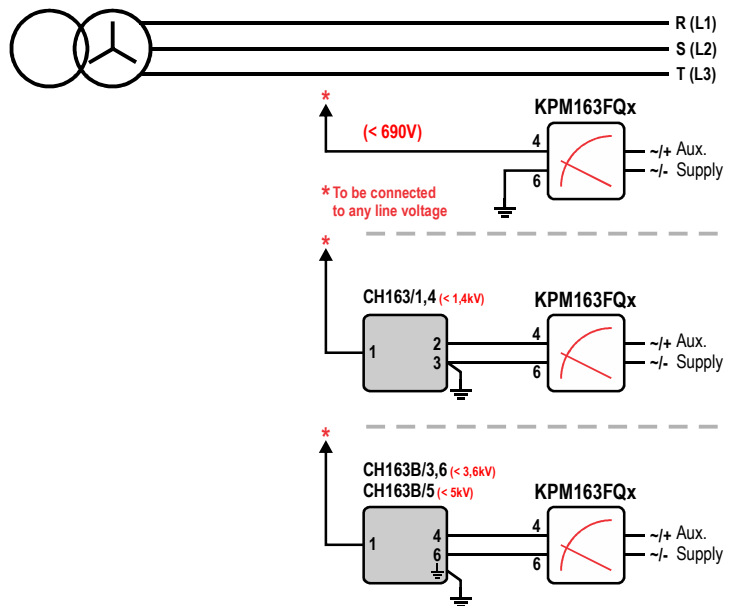

## Dimensions

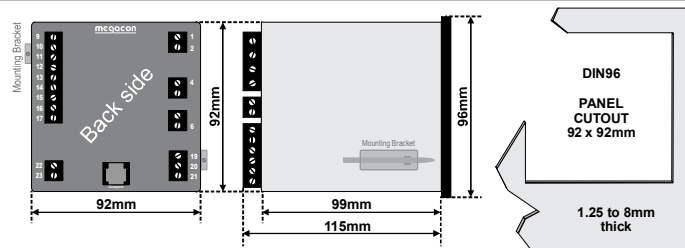

The MEGAICON policy is one of continuous improvement, consequently equipment supplied may vary in detail from this publication.

### ORDERING EXAMPLE:

Type: KPM163FQ  
 Aux. Supply: 200-240VAC  
 Network Voltage: 3,6kVAC  
 Analogue O/P: (O/P3) 4-20mA  
 Range: 0 - 10Mohm

